



User and mounting manual

TT20 + TT20Basic + TT20R +TT20S + TT20RS + TT20SA

Please read also:
SUPPLEMENTARY INSTALLATION INSTRUCTIONS FOR
THE UK MARKET (last 6 pages)

CE approved according to: EN13240
DS (Danish Standard), DIN (Deutsche Industrienorm),
SINTEF (Norwegian Standard) and 15A (Austria)



Congratulations on your new wood-burning stove.
We thank you for choosing a TermaTech wood-burning stove and wish you many cosy and warm moments in the future.

Before using the stove you should read the user and mounting manual and also the SUPPLEMENTARY INSTALLATION INSTRUCTIONS FOR THE UK MARKET (last 6 pages of this manual) so you are familiar with the legal requirements as well as the instructions regarding maintenance. By this it is ensured that the product works as it is intended and you get the most out of your investment for many years to come.

| | | |
|---|-------------|-----------|
| Installation/user instruction..... | Page | 3 |
| Installation instructions in "smoke control areas".. | Page | 6 |
| Lighting instruction..... | Page | 6 |
| Maintenance..... | Page | 8 |
| Warranty/right to invoke lack of conformity..... | Page | 9 |
| Hints..... | Page | 10 |
| Remedy of malfunctions / FAQ..... | Page | 11 |
| Technical specifications..... | Page | 13 |
| Supplementary Inst. Instructions UK..... | Page | 14 |
| Drawing concerning smoke control kit..... | Page | 22 |

INSTALLATION INSTRUCTION

The stove is intended for "intermittent combustion". It is not meant to "heat over" at night. By following the instruction below in "Lighting instruction" the best and most environmentally friendly combustion is achieved.

The wood-burning stove is delivered "ready for mounting" (the exhaust branch may need to be screwed on) and must be connected to the chimney with a smoke pipe. The connection between stove and chimney must, as far as possible, be mounted in one straight piece (with as few bends as possible) and as minimum horizontally, but preferably rising from the stove to the chimney. Joints must be tight. Remember that it has to be possible to clean the pipe (possibly with a cleaning hatch on the pipe).

Any unauthorised changes to the wood-burning stove will be viewed as a structural change and thereby the warranty will be void and is also a risk to safety.

In the door on your TT stove there is a spring that makes the door close by itself when you let go of the handle. This closing device is not a demand in the UK, Denmark and many other countries and can therefore be removed. In the bottom hinge the split with lentic head is removed which removes the tension from the spring. This is most easily done by using a small screw driver and side-cutting pliers.

National and European norms

The regulations in force at the time in question, including those that refer to national and European standards, must be respected when installing the wood-burning stove. Contact your local dealer for further advice and guidance in connection with mounting. Notify your Hetas installer before you use your wood-burning stove. It must be ensured that there is sufficient airflow for the combustion in the stove, so care must be taken concerning closely shut windows and doors that may hinder the flow of air to the combustion.

Safety references

The surface of the stove as well as knobs, handle, window, smoke pipe, etc. become very hot when the stove is in use. Touching these parts without necessary protection (glove or other protective material) can lead to burns.

Remember to make children aware of this danger and make sure to keep them away from the wood-burning stove when it is in use. For this purpose TermaTech offers various grates for the protection of children. (Ask your dealer)

Allowed in the wood-burning stove

Only use dry and clean wood for combustion in the wood-burning stove. Maximum size of logs used in the stove is up to 30 cm in length and 10 cm in diameter.

Only use dry wood. The burning of waste, synthetic materials and

other treated or impregnated materials is not allowed as it is very hazardous to the environment. Furthermore the stove and the chimney will be damaged by these materials. There is a danger of emission of unhealthy substances which can also lead to complaints from neighbours.

Dry and clean wood has a maximum of 20% water which is achieved with outdoor storage for between 1 year (soft wood) and 2 years (hard wood). The wood must be in contact with air during storage so the moisture can get out of the wood.

Firewood is not meant to "burn overnight". Never close off the airflow completely, instead let the fire die out and light it again when you need it.

We warn against closing off the airflow completely. The wood-burning stove can only burn sensibly and environmentally friendly if there is sufficient airflow for the combustion.

Cleaning and checks

The wood-burning stove and the smoke pipe should be checked and cleaned once a year. The chimney must also be cleaned by the chimney sweep who will set the necessary intervals for cleaning / sweeping.

The wood-burning stove should be checked by a professional about once a year.

Ash build up/empty of ashpan

When the stoves have been in use maximum 10 times, it is required to check the ashpan for build up ashes. This is checked by taking the ashpan out of the ash section, shake the ashpan so an even layer is obtained. It is recommended that the ash level is not more than half of the ashpans capacity. If the ash level is more than half the capacity with an even layer, the ashpan is emptied by taken the ash pan out of the ash section, place the ashpan lid on top of the ash pan and empty it. Please be aware of embers in the ashpan, so the disposal of ashes do not start a fire! If the ashpan contains embers the ash must be cooled of, until no embers is present in the ashes.

If no checks of the ash build up in the ashpan is carried out, the grate bars can be damaged and a hazard may occur!

Removal of ashes/charcoal from fire-bed

Before light-up the stove, fire-bed must be cleaned for ashes and bricks of charcoal.

To do this, take the squared metal plate placed on the grate bars out and clean the ashes and charcoals into the ashpan below.

Check for level in ashpan. If ashes is build up – please see item Ash build up/empty of ashpan.

Combustion air

Combustion air is a precondition for a good and clean combustion.

The air is normally taken from the room where the wood-burning stove is mounted, however in some circumstances it may be neces-

sary to provide extra air in the room where the stove is placed. This can e.g. be done by mounting an air valve in the room's outer wall. Air valves that supply necessary combustion air must be kept free from blockage.

An exhaust fan in the same room or close to the wood-burning stove can also have a negative effect on the combustion (at worst it can lead to exhaust gases in the room, even with the stove door closed). Therefore, in the above case, the wood-burning stove and the exhaust fan must never be in use at the same time.

The TT20 models are available with combustion air branch. Ask your dealer for further information.

Adjustable feet:

The enclosed adjustable feet are to be used if the floor is uneven or they can also be used to create the impression that the stove is "flying" / "floating"

Metal plate on the grate:

Delivered with the stove is a metal plate with 4 holes. This plate is to be placed on the cast iron grate. The plate secures the cleanest combustion.

When you clean out ashes remove the plate from the grate and sweep ashes down into the ashdrawer.

Distance to flammable material:

The stove must be put on a non inflammable foundation. This foundation must as a minimum cover 150 mm on each side of the stove and 300 mm in front of the stove.

For inflammable material like inflammable walls made of wood, furniture, etc. the following minimum distances apply for safety reasons:

- 150 mm behind the stove to flammable material. (picture 2)
- 350 mm beside the stove to flammable material. (picture 2)
- 125 mm behind/beside if mounted 45° in a corner (picture 1)
- 1000 mm in front of the stove to flammable material.

Picture 1

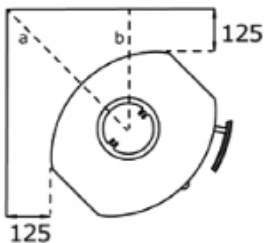

Picture 2

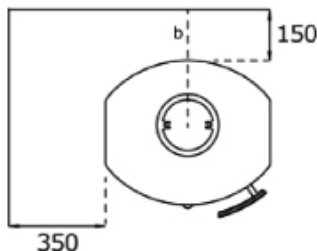

Distance to non-flammable materials:

It is recommended that there is a minimum of 80-100 mm behind and beside the stove so the stove can dispose of the heat, this distance makes cleaning of and around the stove easier. In addition, refer to the relevant Building Regulations.

Requirements for the chimney:

The chimney must be of sufficient height so the draught conditions are okay the smoke does not bother anyone. Good draught in the chimney is crucial to the stove working as intended and burns as environmentally friendly as possible. The height of the chimney must typically be a minimum of 3.5 m from the top of the stove to the top of the chimney.

The chimney must have a minimum internal diameter of Ø150mm. The chimney must be equipped with an easily accessible cleaning hatch. All joints and connections must be tight and the chimney must be able to provide a draught of at least 1.2 mm water gauge (12Pa).

It is possible to connect the wood-burning stove to chimneys that are also used for other purposes. However, the concrete conditions must be assessed by the fitter and/or chimney sweep.

If the stove is to be mounted with **back exit** the following is done: The round, welded or screwed cover plate at the back of the stove is removed. Then the cut-out piece on the base-plate is removed (the thin division plate). Be careful not to drop the piece between the back plate and the stove! This is best done with a screwdriver / chisel or pliers.

Finally the screwed smoke cover is removed and then the exhaust branch can be mounted.

Remember to fix the smoke cover at the top of the stove before use.

Demands for the floor:

The foundation must be able to bear the stove and possibly the chimney's weight.

INSTALLATION INSTRUCTIONS IN SMOKE CONTROL AREAS

Installation in a smoke control area requires the additional assembling / installation of the "Damper control unit" which must be installed by the installer. See drawing and picture on page 19

LIGHTING INSTRUCTION

The first time:

The first time the stove is lit it must be done gently as all the materials need to get use to the heat. The Senotherm varnish that the stove is painted with will harden the first couple of times the stove is heated, and it may cause some odour nuisances. So make sure that you have proper ventilation. Do not touch the painted surface, when

the stove is hot. The painting has to harden up first.

Use of the stove:

Below is the procedure used for testing/approval of the stove. It is this procedure that will lead to the best combustion for the given chimney. Firewood amount and damper setting can be adjusted to the individual need for heating and the draught in the concrete chimney.

On your new TT20 the work with controlling the air input has been simplified so there is only one knob/damper (below the door). Between the left position and the middle position you have the normal area where you control the air input.

No air input = left position and

maximum air input = middle position.

As help for lighting the control knob/damper can be pushed down a little and pushed completely to the right. This start help adds some air from below and ensures faster lighting. After a few minutes the control knob/damper is returned to the normal position (between the left and middle position).

Lighting and continuous firing at EN-testing

1. The ashpan must always be closed completely, also when you light the fire. The damper/start-up device can be opened (the knob is pushed down and to the right) for a few minutes at lighting. Put about 10 kindling sticks (dia. 2-3 cm) in the bottom of the stove, laid in a criss-cross pattern as a log house. Put 2 firelighters in the middle and light them.

2. Leave the door ajar so there is an opening of about 2-3 cm. Leave the stove like that for about 8-10 minutes before you close the door completely. Stay by the stove as long as the door is ajar.

3. When the fire has burned to embers (there are no more flames) open the door gently so the ash is not whirled out through the door. Gently spread out the embers with a poker so they are even.

4. Put 2-3 pieces of firewood in the stove, about 1.7 kg total. The pieces are put in the bottom of the stove and parallel to the front of the stove with equal distance to the stove's sides and with mutual distance of about 1 cm. The front piece is best lit if it has a split side that is turned to the door and one in the embers. Close the door completely immediately.

5. The knob/damper is opened so it is about 2/3 open (between the left and middle position) and after about 2 minutes the damper is set to about 1/3 open. How much the damper should be open depends on the individual chimney's draught, but the flames should now stabilise to a calm fire.

6. When the wood has burned to embers (after about 1 hour) you start again from point 3.

MAINTENANCE – always use original parts

Maintenance and cleaning of the stove should only be performed when the stove is cold. The daily maintenance is limited, but once a year the stove should get thorough maintenance. The combustion chamber should be cleaned for ashes and soot and the door hinges and the closing mechanism should be lubricated with copper grease.

The surface is maintained by brushing it with a soft, long-haired brush or by using the vacuum cleaner with a brush. The stove can also be dusted with a duster. Always remember: only when the stove is cold.

Jointings can look okay, but they collapse under the heat and thereby lose the ability to keep the stove sealed. Jointings should be changed as needed as it is important to good combustion and a clean window that the stove is sealed.

The insulation plates in the combustion chamber that are broken or worn can easily be changed as they are loosely fixed. The material used is called Vermiculite and is a porous, but very suitable insulation material. It has no effect on the stove's efficiency that the insulation cracks. However, it should be changed when the wear surpasses half of the original thickness.

Painting the stove with Senotherm-spray can cover spots or small scratches from kettles and such. Larger damages needs to be ground with fine steel wool, vacuumed and then sprayed. The can has to be shaken vigorously and then sprayed on at a distance of 15-20 cm. It is very important that the stove is not in use and completely cold before you use the spray due to the fire hazard. In order to keep the stove's varnished surfaces looking nice for years to come you should try to avoid touching the varnished surfaces when the stove is hot. Make sure to have sufficient ventilation when using spray paint.

Glass normally does not need any maintenance apart from cleaning. This is most easily done by using TermaTech's glass cleaner. Remember only to use glass cleaner when the stove is cold. Glass is made of ceramic glass, be sure of environmentally disposal.

Original parts which need to be changed due to wear can be found at your dealer. Because of fit etc. only original parts from TermaTech should be used.

Right to claim compensation for defective product is under current law. When stating deviations the use of the product must be suspended immediately and the dealer must be contacted.

Chimney/Flues must be swept on regular occasions, as per manufacturers recommendations.

5 YEAR WARRANTY* / RIGHT TO INVOKE LACK OF CONFORMITY

If defects/faults are ascertained, use of the wood burner must be stopped immediately and the dealer contacted.

***5 Year warranty**

Provided that there has been normal operation of the wood burner, TermaTech offers a 5 year warranty on material and manufacturing faults on the load-bearing frame, exclusive of the combustion chamber.

Combustion chamber: The following parts are not covered by the warranty: The combustion chamber, Cast iron parts (bottom, door and grate), Insulation material (vermiculite plates), Smoke deflector plates, Glass, gaskets as well as the closing mechanism/handle.

Exterior parts: The following parts are not covered by the warranty: Varnished plates/surfaces, stone facings, glazed tiles, concrete and glass as well as the closing mechanism/ handle

The warranty does not cover faults which are due to:

- the user/mounting guide not being followed
- the mounting being carried out incorrectly
- overheating/deterioration of the materials, caused by the use of, for example, the incorrect type of fuel, petroleum coke or too much fuel
- the product has been connected to a chimney with poor drawing qualities, for example, chimneys that are too short or are leaking
- the product being positioned or has been positioned/kept in unheated or damp surroundings
- the product being in bad repair or not maintained in accordance with the instructions
- normal wear and tear of wearing parts/expendable items as well as the varnish
- similar circumstances which are not due to material or manufacturing faults

The lesser defects below, which cannot underlie any claim, can occur in the product:

- naturally occurring variations in the colour nuances and marbling on the soapstone, sandstone and other stone cladding.
- sounds which occur during burning are normal, this occurs when metal expands/retracts.

If a fault occurs during delivery to the customer, or if such a fault arises during the warranty period which is covered by this warranty, TermaTech A/S agrees to send a suitable replacement part free of charge to rectify the fault. Any additional obligation of TermaTech A/S to remedy the fault, for example, in the form of installation of the replacement part, does not exist.

In addition the purchaser has, apart from the right to a replacement part, no right to either direct or indirect damages.

Repairs of faults or replacement of parts on the product do not extend the product or replacement part's warranty period. Neither does a new warranty period begin for the product or replaced part.

Apart from the above warranty rules, the consumer also has those rights which are evident from the obligatory consumer legislation

Any fault or defect must be examined by the vendor who has sold the product. In this case the purchaser must be able to prove that the product has been purchased via the vendor and when it was purchased, for example, in the form of an invoice/receipt. The purchaser must specify the model and production number, which is stated on the product. If the purchaser wishes to refer to a fault, the vendor must be informed within a reasonable time, i.e. 14 days after the defect has been ascertained.

HINTS

Lighting after long break

If the stove has not been used for a long time the chimney should be checked for possible blockage before lighting. Furthermore it is a good idea to remove any dust from the wood-burning stove as it might smell after a long break.

Chimney fire

In case of chimney fire the doors, drawers and damper of the wood-burning stove must be closed immediately in order to shut off the supply of oxygen. The relevant authorities must be notified if necessary. The stove must not be used until the chimney has been inspected.

Kindling is the designation for finely split wood/sticks that are about 20 cm long and have a diameter of 2-3 cm.

Wood like birch, beech, oak, ash, elm, pine wood and wood from fruit trees is all suitable for splitting into firewood.

Waste products like pressure-treated wood, chipboard, coloured brochure or glossy paper must not be used in a wood-burning stove. They develop hydrochloric acid or heavy metals which cause a lot of damage to the stove and the environment.

Firewood should have a diameter of 7-9 cm and be no more than about 30 cm long, otherwise it will get too close to the side of the stove (at the CE-testing firewood at a length of 28 cm was used). The most important thing for good combustion is that the wood is dry (15-20% moisture). If the firewood is too wet it is difficult to get it to burn, the chimney draught is nonexistent, there is a lot of smoke and the exploitation is lower as the water has to evaporate first. Furthermore there may be damage to the stove and the chimney in the shape of shining soot and tarry deposits. At worst it can cause a

chimney fire. If the firewood is too dry it will burn too quickly. Often the gasses in the wood are released faster than they can burn and some go unburned through the chimney. This also gives lower exploitation and harms the environment. So it is a balance that is quite easy to find with a little practise. See also below under Storage.

Bio-briquettes can be used, but they develop a lot of ash and dust. Put in max. 2 kg per hour.

Energy coke must not be used as it contains a lot of sulphur which wears on a stove, the chimney and the environment. The life of stove and chimney will be significantly reduced by using this firing type and the right to claim compensation for the product is void.

Storage of the firewood is best under a roof, however with good ventilation, e.g. in a carport or under a shed roof. Place the wood on a wooden pallet or the like so it is free from the ground. Fresh wood that has been sawed and split must be stored for about 1-2 years this way until the moisture in the wood is down to 15-20%.

The ashes can be put in the rubbish bin for garbage collection. The ashes should always have cooled for 1-2 days before it is put in the rubbish bin, as there might still be embers that can light garbage or a garbage bag.

Regulation and smoke damper:

If one is fixed in the chimney it should not close of more than 80% of the internal diameter of the chimney.

MALFUNCTIONS

If problems should occur with the use of the stove the cause can possibly be found below. If not, then you are always welcome to contact your dealer.

The stove is difficult to control – it burns too fast

If the stove is new, then check that the directions have been followed. If the stove is more than 1 year old or if it has been used heavily, then the jointings may need to be changed. If the jointings sit for too long the heat makes them lose their ability to keep the stove sealed. Check that the ashpan is closed completely.

If there is heavy draught in the chimney it may be necessary to fit a damper in it.

The stove has poor draught after installation

Check that the mounting instructions have been followed. It is especially the conditions surrounding the chimney that may cause problems. Are diameter and length okay, is it sealed, are smoke pipe and junctions sealed? Is the cleaning hatch sealed? You may need to contact a chimney sweep to remedy the problem as the chimney

may be blocked.

Smoke at soot smell

This can be caused by down-draught in the chimney and most often happens in specific wind directions. The chimney may be too short for the ridge or trees may have grown and are creating turbulence. Remember not to open the door while there are flames.

The stove is difficult to light and may die out

There may be a number of causes. The most typical are:

The damper is not sufficiently open.

The firewood is too wet.

The draught in the chimney is too small or maybe it is blocked or leaking.

The ember layer was too small/incinerated and did not give enough heat to light the logs. Possibly give some start-up air to the fire by opening the damper (pushed down and to the right) to get the stove going again. Then the damper has to be closed again (back to position between left and the middle).

Depending on the problem it may be necessary to contact the dealer, installer or a chimney sweep.

The glass soots up

The wood is too moist.

Lack of draught in the chimney.

Check that the damper is not closed.

Door is closed too early at lighting (point 3 section 2).

TECHNICAL SPECIFICATIONS

| | TT20 | TT20R | TT20Basic |
|----------------------|-------------|--------------|------------------|
| Nominal heat output: | 5 kW | 5 kW | 5 kW |
| Height: | 1053mm | 1053mm | 958mm |
| Width: | 478mm | 531mm | 478mm |
| Depth: | 419mm | 419mm | 419mm |
| Weight: | ca. 118kg | ca. 119kg | ca. 100kg |

| | TT20S+SA | TT20RS |
|----------------------|-----------------|---------------|
| Nominal heat output: | 5 kW | 5 kW |
| Height: | 1088mm | 1088mm |
| Width: | 470mm | 531mm |
| Depth: | 419mm | 419mm |
| Weight: | ca. 155kg | ca. 177kg |

Average values for testing of TT20 models:

| | |
|-------------------------|---------|
| Exhaust gas temperature | 273 °C |
| Exhaust gas mass flow | 4.0 g/s |
| Efficiency | 83,4% |
| Nominal Heat output | 5 kW |
| Flue draught | 12 Pa |

SUPPLEMENTARY INSTALLATION INSTRUCTIONS UK

READ THE INSTRUCTION BOOKLET AND THESE SUPPLEMENTARY INSTRUCTIONS CAREFULLY BEFORE INSTALLATION

These instructions together with those in the instruction booklet cover the basic principles to ensure the satisfactory installation of the stove, although detail may need slight modification to suit particular local site conditions.

In all cases the installation must comply with current Building Regulations, Local Authority Byelaws and other specifications or regulations as they affect the installation of the stove.

It should be noted that the Building Regulations requirements may be met by adopting the relevant recommendations given in British Standards BS 8303, BS EN 15287-1:2007 as an alternative means to achieve an equivalent level of performance to that obtained following the guidance given in Approved Document J.

Please note that it is a legal requirement under England and Wales Building Regulations that the installation of the stove is either carried out under Local Authority Building Control approval or is installed by a Competent Person registered with a Government approved Competent Persons Scheme. HETAS Ltd operate such a Scheme and a listing of their Registered Competent Persons can be found on their website at www.hetas.co.uk.

CO Alarms:

Building regulations require that when ever a new or replacement fixed solid fuel or wood/biomass appliance is installed in a dwelling a carbon monoxide alarm must be fitted in the same room as the appliance. Further guidance on the installation of the carbon monoxide alarm is available in BS EN 50292:2002 and from the alarm manufacturer's instructions. Provision of an alarm must not be considered a substitute for either installing the appliance correctly or ensuring regular servicing and maintenance of the appliance and chimney system.

The Clean Air Act 1993 and Smoke Control Areas

Under the Clean Air Act local authorities may declare the whole or part of the district of the authority to be a smoke control area. It is an offence to emit smoke from a chimney of a building, from a furnace or from any fixed boiler if located in a designated smoke control area. It is also an offence to acquire an "unauthorised fuel" for use within a smoke control area unless it is used in an "exempt" appliance ("exempted" from the controls which generally apply in the smoke control area).

The Secretary of State for Environment, Food and Rural Affairs has powers under the Act to authorise smokeless fuels or exempt appliances for use in smoke control areas in England. In Scotland and

Wales this power rests with Ministers in the devolved administrations for those countries. Separate legislation, the Clean Air (Northern Ireland) Order 1981, applies in Northern Ireland. Therefore it is a requirement that fuels burnt or obtained for use in smoke control areas have been "authorised" in Regulations and that appliances used to burn solid fuel in those areas (other than "authorised" fuels) have been exempted by an Order made and signed by the Secretary of State or Minister in the devolved administrations.

The TermaTech TT20, TT20Bazic, TT20R, TT20S and TT20RS have been recommended as suitable for use in smoke control areas when burning wood logs and when fitted with a damper control unit to prevent closure of the air control lever beyond the 22mm open position.

Further information on the requirements of the Clean Air Act can be found here: <http://smokecontrol.defra.gov.uk/>

HEALTH AND SAFETY PRECAUTIONS

Special care must be taken when installing the stove such that the requirements of the Health and Safety at Work Act are met.

Handling

Adequate facilities must be available for loading, unloading and site handling.

Fire Cement

Some types of fire cement are caustic and should not be allowed to come into contact with the skin. In case of contact wash immediately with plenty of water.

Asbestos

This stove contains no asbestos. If there is a possibility of disturbing any asbestos in the course of installation then please seek specialist guidance and use appropriate protective equipment.

Metal Parts

When installing or servicing this stove care should be taken to avoid the possibility of personal injury.

STOVE PERFORMANCE

Please refer to the table in the main instruction manual for details of the stoves' performances

PREPARATORY WORK AND SAFETY CHECKS

IMPORTANT WARNING

This stove must not be installed into a chimney that serves any other heating appliance.

There must not be an extractor fan fitted in the same room as the

stove as this can cause the stove to emit fumes into the room.

Chimney

In order for the stove to perform satisfactorily the chimney height must be sufficient to ensure an adequate draught of approximately 15 Pa so as to clear the products of combustion and prevent smoke problems into the room.

NOTE: A chimney height of not less than 4.5 metres measured vertically from the outlet of the stove to the top of the chimney should be satisfactory. Alternatively the calculation procedure given in EN 13384-1 may be used as the basis for deciding whether a particular chimney design will provide sufficient draught.

The outlet from the chimney should be above the roof of the building in accordance with the provisions of Building Regulations Approved Document J.

If installation is into an existing chimney then it must be sound and have no cracks or other faults which might allow fumes into the house. Older properties, especially, may have chimney faults or the cross section may be too large i.e. more than 230 mm x 230 mm. Remedial action should be taken, if required, seeking expert advice, if necessary. If it is found necessary to line the chimney then a flue liner suitable for solid fuel must be used in accordance with Building Regulations Approved Document J.

Any existing chimney must be clear of obstruction and have been swept clean immediately before installation of the stove. If the stove is fitted in place of an open fire then the chimney should be swept one month after installation to clear any soot falls which may have occurred due to the difference in combustion between the stove and the open fire.

If there is no existing chimney then any new system must be to the designation described above and in accordance with Building Regulations Approved Document J.

A single wall metal fluepipe is suitable for connecting the stove to the chimney but is not suitable for use as the complete chimney. The chimney and connecting fluepipe must have a minimum diameter of 150 mm and its dimension should be not less than the size of the outlet socket of the stove.

Any bend in the chimney or connecting fluepipe should not exceed 45°. 90° bends should not be used.

Combustible material should not be located where the heat dissipating through the walls of fireplaces or flues could ignite it. Therefore when installing the stove in the presence of combustible materials due account must be taken of the guidance on the separation of combustible material given in Building Regulations Approved Document J and also in these stove instructions.

If it is found that there is excessive draught in the chimney then a draught stabiliser should be fitted. Fitting of a draught stabiliser will affect the requirement for the permanent air supply into the room in which the stove is fitted in accordance with Approved Document J (see also combustion air supply).

Adequate provision e.g. easily accessible soot door or doors must be provided for sweeping the chimney and connecting fluepipe where it is not intended for the chimney to be swept through the appliance.

Hearth

The hearth should be able to accommodate the weight of the stove and its chimney if the chimney is not independently supported. The weight of the stove is indicated in the brochure.

The stove should preferably be installed on a non-combustible hearth of a size and construction that is in accordance with the provisions of the current Building Regulations Approved Document J.

The clearance distances to combustible material beneath, surrounding or upon the hearth and walls adjacent to the hearth should comply with the guidance on the separation of combustible material given in Building Regulations Approved Document J and also in these stove instructions.

If the stove is to be installed on a combustible floor surface, it must be covered with a non-combustible material at least 12mm thick, in accordance with Building Regulations Approved Document J, to a distance of 30 cm in front of the stove and 15 cm to each side measuring from the door of the combustion chamber.

Combustion air supply

In order for the stove to perform efficiently and safely there must be an adequate air supply into the room in which the stove is installed to provide combustion air. The provision of air supply to the stove must be in accordance with current Building Regulations Approved Document J. An opening window is not appropriate for this purpose.

Connection to chimney

Stoves may have a choice of either a rear or top flue gas connector that allows connection to either a masonry chimney or a prefabricated factory made insulated metal chimney in accordance with their instructions. In some cases it may be necessary to fit an adaptor to increase the diameter of the flue to the minimum required 150 mm section of the chimney or liner.

Commissioning and handover

Ensure all parts are fitted in accordance with the instructions.

On completion of the installation allow a suitable period of time for any fire cement and mortar to dry out, before lighting the stove. Once the stove is under fire check all seals for soundness and check

that the flue is functioning correctly and that all products of combustion are vented safely to atmosphere via the chimney terminal. On completion of the installation and commissioning ensure that the operating instructions for the stove are left with the customer. Ensure to advise the customer on the correct use of the appliance and warn them to use only the recommended fuel for the stove.

Advise the user what to do should smoke or fumes be emitted from the stove. The customer should be warned to use a fireguard to BS 8423:2002 (Replaces BS 6539) in the presence of children, aged and/or infirm persons.

READ THE INSTRUCTION BOOK AND THESE INSTRUCTIONS CAREFULLY BEFORE USING THE STOVE

WARNING NOTE

Properly installed, operated and maintained this stove will not emit fumes into the dwelling. Occasional fumes from de ashing and re fuelling may occur. However, persistent fume emission is potentially dangerous and must not be tolerated. If fume emission does persist, then the following immediate action should be taken:

- (a) Open doors and windows to ventilate the room and then leave the premises.
- (b) Let the fire go out.
- (c) Check for flue or chimney blockage and clean if required
- (d) **Do not attempt to relight the fire until the cause of the fume emission has been identified and corrected. If necessary seek expert advice.**

The most common cause of fume emission is flueway or chimney blockage. For your own safety these must be kept clean at all times.

IMPORTANT NOTES

General

Before lighting the stove check with the installer that the installation work and commissioning checks described above have been carried out correctly and that the chimney has been swept clean, is sound and free from any obstructions. As part of the stoves' commissioning and handover the installer should have shown you how to operate the stove correctly.

CO Alarm

Your installer should have fitted a CO alarm in the same room as the appliance. If the alarm sounds unexpectedly, follow the instructions given under "Warning Note" above.

Use of fireguard

When using the stove in situations where children, aged and/or infirm persons are present a fireguard must be used to prevent accidental contact with the stove. The fireguard should be manufactured in accordance with BS 8423:2002 (Replaces BS 6539).

Chimney cleaning

The chimney should be swept at least twice a year. It is important that the flue connection and chimney are swept prior to lighting up after a prolonged shutdown period.

If the stove is fitted in place of an open fire then the chimney will require sweeping after a month of continuous operation. This is a precaution to ensure that any "softer" deposits left from the open fire usage have not been loosened by the higher flue temperatures generated by the closed stove.

In situations where it is not possible to sweep through the stove the installer will have provided alternative means, such as a soot door. After sweeping the chimney the stove flue outlet and the flue pipe connecting the stove to the chimney must be cleaned with a flue brush.

Periods of Prolonged Non-Use

If the stove is to be left unused for a prolonged period of time then it should be given a thorough clean to remove ash and unburned fuel residues. To enable a good flow of air through the appliance to reduce condensation and subsequent damage, leave the air controls fully open.

Extractor fan

There must not be an extractor fan fitted in the same room as the stove as this can cause the stove to emit smoke and fumes into the room.

Aerosol sprays

Do not use an aerosol spray on or near the stove when it is alight.

Use of operating tools

Always use the operating tools provided when handling parts likely to be hot when the stove is in use.

Refuelling on to a low fire bed

If there is insufficient burning material in the firebed to light a new fuel charge, excessive smoke emission can occur. Refuelling must be carried out onto a sufficient quantity of glowing embers and ash that the new fuel charge will ignite. If the fire bed is too low or cool, suitable kindling must be used to re-light fires

Fuel overloading

The maximum amount of fuel specified in this manual should not be exceeded, overloading can cause excess smoke.

Use with door left open

Operation with the door open can cause excess smoke. The appliance must not be operated with the appliance door left open except as directed in the instructions.

Dampers left open

Operation with the air controls or dampers open can cause excess smoke. The appliance must not be operated with air controls or dampers left open except as directed in the instructions.

Chimney Fires

If the chimney is thoroughly and regularly swept, chimney fires should not occur. However, if a chimney fire does occur turn off the stove immediately and isolate the mains electricity supply (if applicable), and tightly close the doors of the stove. This should cause the chimney fire to go out. If the chimney fire does not go out when the above action is taken then the fire brigade should be called immediately. Do not relight the stove until the chimney and flueways have been cleaned and examined by a professional.

Permanent air vent

The stove requires a permanent and adequate air supply in order for it to operate safely and efficiently.

In accordance with current Building Regulations the installer may have fitted a permanent air supply vent into the room in which the stove is installed to provide combustion air. This air vent should not under any circumstances be shut off or sealed.

USER OPERATING INSTRUCTIONS

Please read the important notices given above before referring to the main instruction book for detailed operating instructions.

Recommended fuels

Stoves may be designed to burn dry seasoned wood logs and/or

solid mineral fuel as indicated in the main stove manuals.

HETAS Ltd Approval

HETAS approval may be limited to specific fuel types as detailed in the main instruction manuals. Approval does not cover the use of other fuels either alone or mixed with the recommended fuel, nor does it cover instructions for the use of other fuels.

Damper control unit for smoke control areas

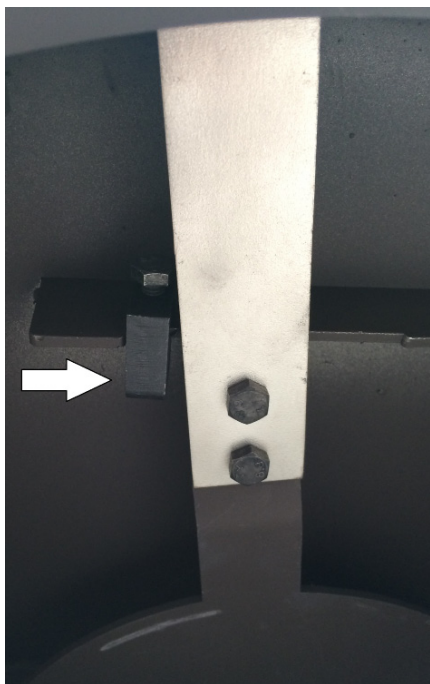
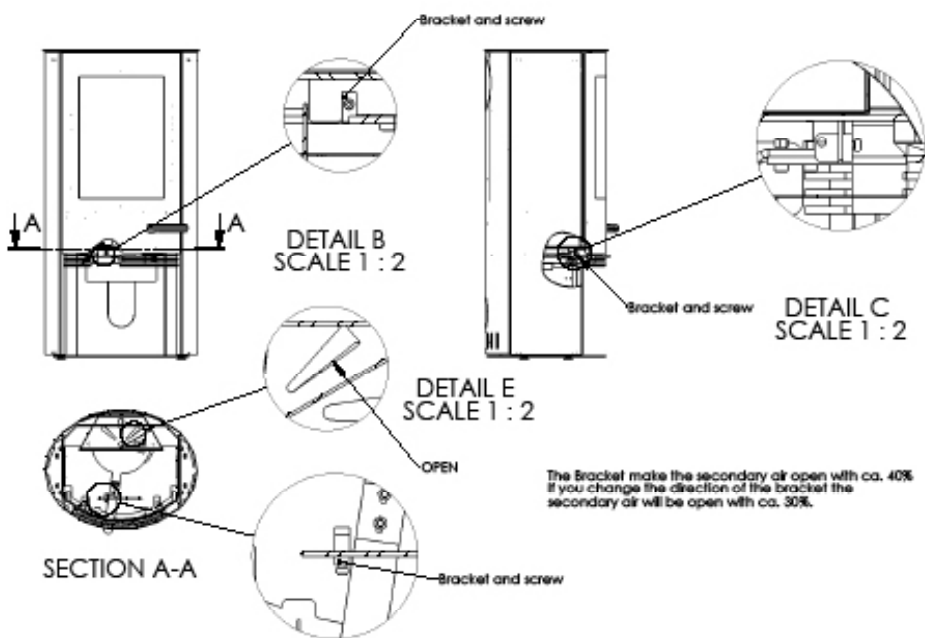

UK

This installation and user guide with related claim and warranty provisions, concerns TermaTech wood-burning stove:

Model: _____

Productions/serialnumber: _____

Purchased on: _____



TermaTech AS • Denmark
www.termatech.com